

Monogram.

Use and Care Guide

for 48"

Built-In

Refrigerator

b-22

1993 Monogram.™

ZIS48N

ZISB48D

ZISW48D

Introduction

Your new Monogram refrigerator makes an eloquent statement of style, convenience and kitchen planning flexibility. Whether you chose it for its purity of design, practical storage arrangements or assiduous attention to detail—or for all of these reasons—you'll find that your Monogram refrigerator's superior blend of form and function will delight you for years to come.

The Monogram refrigerator was designed to provide the flexibility to blend in with your kitchen cabinetry. Decorative door insert panels allow it to match your kitchen cabinets or blend with your kitchen decor. Custom handles are also available to further personalize your refrigerator. Through a series of product and trim kit choices, the Monogram refrigerator can be beautifully integrated into the kitchen.

Since this is designed to be a built-in product, custom panels are required on the front of the Monogram refrigerator. Consult your kitchen designer or cabinetmaker for your customized look.

The information on the following pages will help you operate and maintain your refrigerator properly.

For more information, please refer to the following publications:

24-M002

Product Planning and Installation Information

49-6457

Installation Instructions

49-6458

Trim Options and Instructions

These can be obtained from a GE Monogram dealer. For a listing of dealers—or if you have other questions—please call the GE Answer Center® (800.626.2000).

Contents

Appliance Registration	3	Model and Serial Numbers	3
Care and Cleaning	13-16	Power Saver Switch	5
Condenser	14	Problem Solver	18-20
Drawer/Cover Removal	16	Safety Instructions	4
Light Bulb Replacement	15	Shelves	12
Vacation Tips	16	Storage Drawers	11
Consumer Services	22	Temperature Controls	5
Food Storage Suggestions	10	Water Filter Accessory	9
Storage Times	10	Warranty	23
Ice and Water Dispenser	6-9		
Installation	17		
Adapter Plug	17		
Clearances	17		
Electrical Requirements	17		
Grounding	17		
Leveling	17		

Read this book carefully.

It is intended to help you operate and maintain your new refrigerator properly.

Keep it handy for answers to your questions.

If you don't understand something or need more help, write (include your phone number):

Consumer Affairs
GE Appliances
Appliance Park
Louisville, KY 40225

Write down the model and serial number.

You'll see them on a label on the right side, near the bottom of the fresh food compartment.

These numbers are also on the Consumer Product Ownership Registration Card that came with your refrigerator. Before sending in this card, please write these numbers here:

Model Number

Serial Number

Use these numbers in any correspondence or service calls concerning your refrigerator.

If you received a damaged refrigerator...

Immediately contact the dealer (or builder) that sold you the refrigerator.

Save time and money. Before you request service...

Check the Problem Solver in the back of this book. It lists causes of minor operating problems that you can correct yourself.

If you need service...

To obtain service, see the Consumer Services page in the back of this book.

We're proud of our service and want you to be pleased. If for some reason you are not happy with the service you receive, here are three steps to follow for further help.

FIRST, contact the people who serviced your appliance. Explain why you are not pleased. In most cases, this will solve the problem.

NEXT, if you are still not pleased, write all the details—including your phone number—to:

Manager, Consumer Relations
GE Appliances
Appliance Park
Louisville, KY 40225

FINALLY, if your problem is still not resolved, write:

Major Appliance Consumer
Action Panel
20 North Wacker Drive
Chicago, IL 60606

IMPORTANT SAFETY INSTRUCTIONS

Read All Instructions Before Using This Appliance.



WARNING—When using this appliance, always exercise basic safety precautions, including the following:

- **Use this appliance only for its intended purpose** as described in this Use and Care Guide.

-
- **This refrigerator must be properly installed in accordance with the Installation Instructions before it is used.** See the Grounding Instructions.

-
- **After your refrigerator is in operation, do not touch the cold surfaces in the freezer compartment, particularly when hands are damp or wet.** Skin may adhere to these extremely cold surfaces.

- **Do not place fingers or hands on the automatic icemaking mechanism while the refrigerator is plugged in.** This will help protect you from possible injury. It will also prevent interference with the moving parts of the ejector mechanism, or with the heating element that releases the cubes.

-
- **Do not allow children to climb, stand or hang on the shelves in the refrigerator.** They could damage the refrigerator and seriously injure themselves.

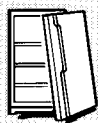

- **If your old refrigerator is still around the house but not in use, be sure to remove the doors.** This will reduce the possibility of danger to children.

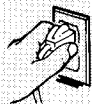

- **Unplug your refrigerator before cleaning and making repairs.**
NOTE: We strongly recommend that any servicing be performed by a qualified individual.

- **Before replacing a burned-out light bulb, unplug the refrigerator or turn off power at the circuit breaker or fuse box** in order to avoid contact with a live wire filament. (A burned-out light bulb may break when being replaced.)
NOTE: Turning freezer compartment temperature control to OFF position does not remove power to the light circuit.

- **Don't refreeze frozen foods which have thawed completely.** The United States Department of Agriculture in Home and Garden Bulletin No. 69 says:

“...You may safely refreeze frozen foods that have thawed if they still contain ice crystals or if they are still cold—below 40°F.

“...Thawed ground meats, poultry or fish that have any off-odor or off-color should not be refrozen and should not be eaten. Thawed ice cream should be discarded. If the odor or color of any food is poor or questionable, get rid of it. The food may be dangerous to eat.

“...Even partial thawing and refreezing reduce the eating quality of foods, particularly fruits, vegetables and prepared foods. The eating quality of red meats is affected less than that of many other foods. Use refrozen foods as soon as possible to save as much of their eating quality as you can.”

-
- **Do not operate your refrigerator in the presence of explosive fumes.**

- **Do not store or use gasoline or other flammable vapors and liquids in the vicinity of this or any other appliance.**

SAVE THESE INSTRUCTIONS

OPERATING YOUR REFRIGERATOR

Set Temperature Controls

Your refrigerator has two controls that let you regulate the temperature in the fresh food and freezer compartments.

They have settings from 1 through 9, and are located at the top of the fresh food compartment.

The freezer control also has an OFF setting.

9 is the coldest setting, 1 is the warmest.



WHEN YOU FIRST TURN THE REFRIGERATOR ON, SET BOTH CONTROLS AT 5.

For colder or warmer temperatures, adjust the desired compartment control one number at a time.

IMPORTANT: When first setting controls, or adjusting them, allow 24 hours for the refrigerator to get cold.

NOTE: Turning the freezer control to the OFF position stops cooling in BOTH compartments—fresh food AND freezer—but does not shut off power to the refrigerator.

How to Test Temperatures

Use the milk test for the fresh food compartment. Place a container of milk on the top shelf in the fresh food compartment. Check it a day later. If the milk is too warm or too cold, adjust the temperature controls.

Use the ice cream test for the freezer compartment. Place a container of ice cream in the center of the freezer compartment. Check it after a day. If it's too hard or too soft, adjust the temperature controls.

Always allow 24 hours for the refrigerator to reach the temperature you set.

Power Saver Switch

The power saver switch is located on the temperature control panel.

To reduce the amount of electricity required to operate your refrigerator, push switch to POWER SAVER setting.

This turns off the heater in your refrigerator that prevents moisture from forming on the outside of the refrigerator.

With the heater turned off, there is a chance that moisture may form on the outside of your refrigerator, especially when the weather is humid.

The humidity is most likely to be high in the summer, in the early morning hours, and in homes which are not air conditioned.

Over an extended period of time, moisture that forms on the refrigerator surface may cause deterioration of the paint finish. It will be important to protect the finish by using appliance polish wax as described in the Care and Cleaning section.

Move the power saver switch from the POWER SAVER setting and electricity flows through the low wattage heater which warms the outside of the refrigerator. Under most conditions, this prevents the forming of moisture or water droplets.

No Defrosting

It is not necessary to defrost the freezer or fresh food compartments. Although your refrigerator is designed and equipped to defrost itself automatically, some frost on packages is normal.

ICE & CHILLED WATER DISPENSER

(on some models)

Automatic Icemaker and Ice & Chilled Water Dispenser

Some models have an automatic icemaker and a dispenser that dispenses chilled water, ice cubes and crushed ice through the freezer compartment door. Here's how they work.

Water flows from the household supply through a

- (1) dual solenoid valve to the
- (2) water reservoir and to the
- (3) automatic icemaker as needed.

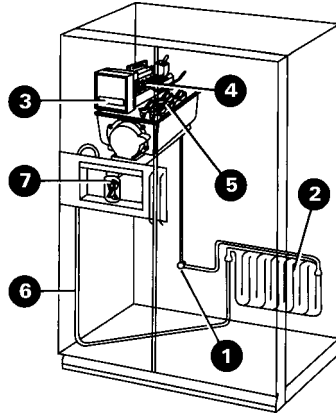

Water is frozen in the

- (4) cube mold and ejected into the
- (5) storage bin where a motor-powered auger moves cubes forward into the dispensing unit. Cubes or crushed ice, as selected, dispense through chute in door when cradle is pressed.

When the switch is moved to CRUSHED, the baffle in housing channels cubes through the crusher and crushed ice falls through chute into glass.

Chilled water from reservoir flows through the

- (6) tubing in the door and is dispensed when the cradle is pressed.
- (7) **A light switch** turns the night light in the dispenser on and off.

Important Facts About Your Ice & Chilled Water Dispenser

- **Your icemaker will produce eight cubes per cycle**—approximately 120 cubes in a 24-hour period—depending on freezer compartment temperature, room temperature, number of door openings and other use conditions.
- **Intermittent dispensing of ice is normal.** If ice flow interruption is more than brief, ice clump(s) may be the cause and should be removed.
- **Avoid overfilling glasses with ice and using narrow or extra-tall glasses.** This can jam the chute or cause the door in the chute to freeze shut. Periodically open the freezer compartment door and look down into the chute. If ice is blocking the chute, poke it through with a wooden spoon.
- **To help keep bits of ice from being sprayed beyond the glass, place glass close to ice chute**—but not so close that it blocks outcoming ice.
- **Beverages and foods should not be quick-chilled in the ice storage bin.** Cans, bottles or food packages in the storage bin may cause the icemaker to malfunction.
- **Ice other than that produced by your icemaker should not be added to the ice storage bin**—it may not crush or dispense well.

Before Using Your Icemaker and Dispenser

If you use your refrigerator before the water connection is made, raise the ice access door and make sure the icemaker feeler arm is in the STOP (up) position as shown below.

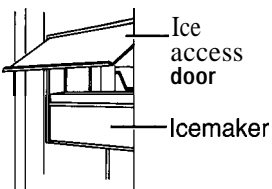

When water supply has been connected to icemaker, move feeler arm to ON (down) position.

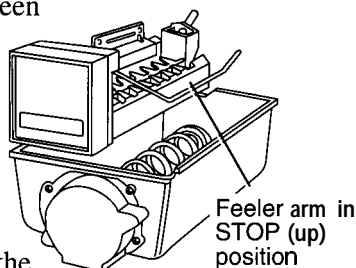

Move selector switch to CHILLED WATER and depress dispenser cradle for about two minutes to remove trapped air from the water line and to fill water reservoir automatically.

Ice cube mold automatically fills with water after cooling to freezing temperatures. First cubes normally freeze after several hours.

NOTE: With a newly-installed refrigerator, allow about 24 hours for the freezer compartment to cool down to the proper ice-making temperature.

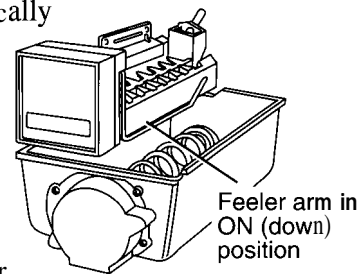

Once Your Icemaker and Dispenser are in Operation

Throw away the first few batches of ice cubes (16 or 24 cubes). This will flush away any impurities in the water line. Do the same thing after vacations or extended periods when ice isn't used.

Discard the first six glassfuls of water in the kitchen sink. This will eliminate the slight "plastic" taste temporarily imparted to the water by the water reservoir.

Keep ice level to keep icemaker productive. Cubes ejected into an empty storage bin will pile up close to the icemaker and push the feeler arm up to the STOP position prematurely when the bin is only partially full. Open the ice access door, reach in, level the cubes by hand and icemaking will resume. Keeping cubes distributed evenly will allow the icemaker to produce enough ice to fill the bin to its maximum capacity.

Caution:

Under certain rare circumstances, ice cubes may be discolored, usually appearing with a green-bluish color. The cause of this unusual discoloration is apparently due to a combination of factors such as certain characteristics of local waters, household plumbing and the accumulation of copper salts in an inactive water supply line which feeds the icemaker. Continued consumption of such discolored ice cubes maybe injurious to health. If such discoloration is observed, discard the ice cubes and contact your GE Factory Service Center or an authorized Customer Care® Servicer.

To Dispense Ice and Water

For ice, set selector switch to CUBED, CRUSHED or CHILLED WATER.

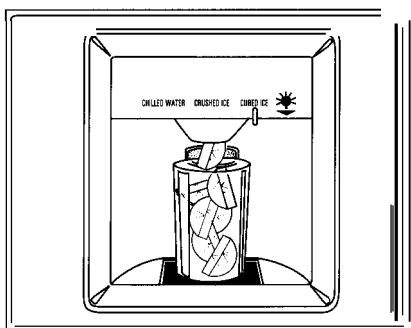

Grip glass or other container gently near the rim and press rim firmly against dispenser cradle.

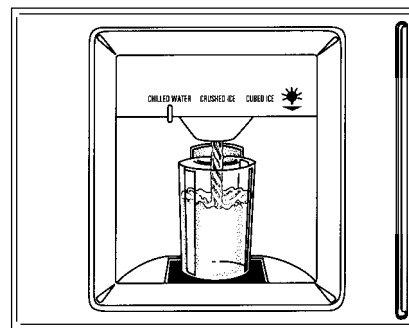

CAUTION: Never put fingers or other objects into the ice crusher discharge opening.

(continued next page)

ICE & CHILLED WATER DISPENSER

(continued)

When Dispensing Ice...

Some crushed ice may be dispensed even though you selected CUBED. This happens occasionally when a few cubes accidentally get channeled to the crusher.

Sometimes a mound of snow will form on the door in the ice chute. This condition is normal, and usually occurs when you have dispensed crushed ice repeatedly. The snow will eventually evaporate.

When Dispensing Water...

The water system provides approximately six successive 6-ounce glassfuls—after which several hours must be allowed for replenished water reservoir supply to cool. You probably will not drain all the chilled water from the reservoir on a single occasion.

The first glass of water dispensed maybe warmer than the following ones. This is normal.

Dispensed water is chilled, not iced. For colder water, simply add crushed ice or cubes before dispensing water.

To Stop Dispensing

Release pressure from cradle and withdraw slowly to catch last bits of ice or drops of water.

Some slight dripping may occur following dispensing of crushed ice or chilled water. If excessive, the spill should be wiped dry immediately.

Do not pour water in spill shelf because it is not self-draining—pour it in the kitchen sink. The shelf and its grille should be cleaned regularly according to the Care and Cleaning section.

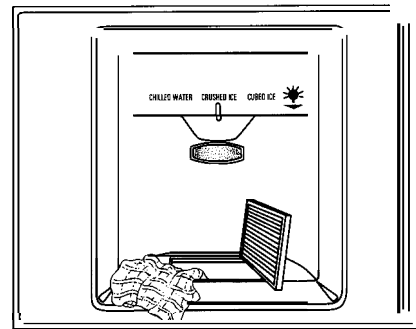

If Ice Clumps Form in Storage Bin...

The icemaker ejects cubes in groups of eight, and it is normal for several cubes to be joined together.

However, **infrequent usage of ice can cause ice clumps to form in the storage bin**, resulting in temporary malfunction of the dispenser mechanism.

If this happens:

- Remove storage bin from freezer compartment.
- Break up ice clumps with fingertip pressure and discard remaining clumps.
- Replace bin before remaining cubes melt and fuse together.

To Remove Ice Cube Storage Bin

Lift the left corner to free the bin from the shelf, and pull the bin straight out while supporting it at front and back.

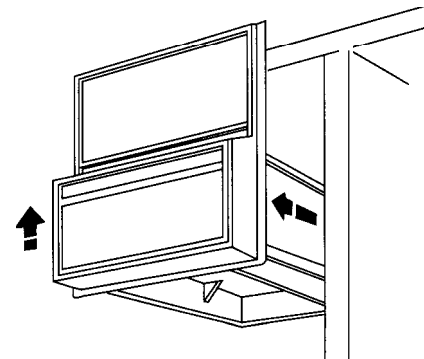

To Replace Ice Cube Storage Bin

Slide the bin back until the tab on the bin locks into the slot in the shelf.

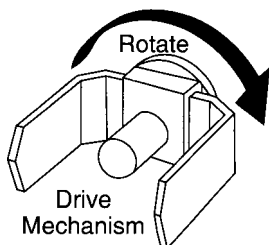

If the bin does not go all the way back, remove it and rotate the drive mechanism 1/4 turn. Then push bin back again until the tab on the bin locks into the slot in the shelf.

If Ice Is Not Used Frequently . . .

“Old” ice cubes will become cloudy and taste stale. Empty ice storage bin periodically and wash it in lukewarm water. Be sure to allow storage bin to cool before replacing it—otherwise ice cubes will stick to the metal auger.

Move Icemaker Feeler Arm to STOP (up) Position When...

- Home water supply is to be turned off for several hours.
- Ice storage bin is to be removed for a period of time.
- Going away on vacation, at which time you should also turn off the valve in the water supply line to your refrigerator.

If This Is Your First Icemaker...

You'll hear occasional sounds that may be unfamiliar. These are normal icemaking sounds and are not cause for concern.

Water Filter Accessory

The perfect companion to your automatic icemaker—a water filter.

Your ice cubes can only be as fresh-tasting as the water that produces them. That's why it's a good idea to purify your water with a water filter.

REMOVES SEDIMENT

Rigid, porous graded density depth cellulose fiber cartridge catches dirt, rust particles, sand and silt.

REMOVES ODORS

Activated charcoal granules remove musty, stale odors.

IMPROVES TASTE

Activated charcoal granules remove oily, medicinal, plastic and metallic tastes.

REDUCES SCALE

Special crystals reduce hard scale deposit formation.

The water filter is an option at extra cost and is available from your GE dealer. Specify WR97X0214. It has complete installation instructions and installs in minutes on 1/4" O.D. copper water line.

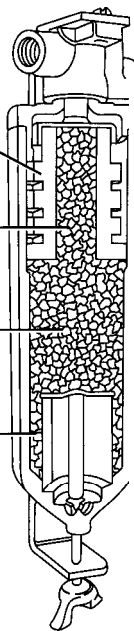

FOOD STORAGE SUGGESTIONS

Suggested storage times for meat and poultry*

Eating quality drops after time shown	DAYS IN MONTHS IN		Eating quality drops after time shown	DAYS IN MONTHS IN	
	REFRIGERATOR	FREEZER		REFRIGERATOR	FREEZER
	AT 35° to 40°F. AT 0°F.			AT 35° to 40°F. AT 0°F.	
Fresh Meats					
Roasts (Beef & Lamb)	3 to 5	6 to 12			
Roasts (Pork & Veal)	3 to 5	4 to 8			
Steaks (Beef)	3 to 5	6 to 12			
Chops (Lamb)	3 to 5	6 to 9			
Chops (Pork)	3 to 5	3 to 4			
Ground & Stew Meats	1 to 2	3 to 4			
Variety Meats	1 to 2	3 to 4			
Sausage (Pork)	1 to 2	1 to 2			
Processed Meats					
Bacon	7	1			
Frankfurters	7	½			
Ham (Whole)	7	1 to 2			
Ham (Half)	3 to 5	1 to 2			
Ham (Slices)	3	1 to 2			
Luncheon Meats	3 to 5	Freezing			
Sausage (Smoked)	7	not recom-			
Sausage (Dry & Semi-Dry)	14 to 21	mended.			

(Other than for meats & poultry) FREEZER

Most fruits and vegetables.....	8-12 months
Lean fish	6-8 months
Fatty fish, rolls and breads, soups, stew, casseroles	2-3 months
Cakes, pies, sandwiches, leftovers (cooked), ice cream (original carton)	1 month max.

**U.S. Department of Agriculture*

Meats, fish and poultry purchased from the store vary in quality and age; consequently, safe storage time in your refrigerator will vary.

Fresh Food Storage Tips

To store unfrozen meats, fish and poultry:

- Always remove store wrappings.
- Rewrap in foil, plastic wrap or wax paper and refrigerate immediately.

To store vegetables, use the vegetable drawers— they've been designed to preserve the natural moisture and freshness of produce.

- Covering vegetables with a moist towel helps maintain crispness.

- As a further aid to freshness, prepackaged vegetables can be stored in their original wrapping.

To store cheese, wrap well with wax paper or aluminum foil, or put in a plastic bag.

- Carefully wrap to expel air and help prevent mold.
- Store prepackaged cheese in its own wrapping if you wish.

New techniques are constantly being developed. Consult the County Extension Service or your local Utility Company for the latest information on freezing and storing foods.

Tips on Freezing Food

There are three essential requirements for efficient home freezing.

- 1. Initial quality.** Freeze only top-quality foods. Freezing retains quality and flavor; it cannot improve quality.
- 2. Speed.** The quicker fruits and vegetables are frozen after picking, the better the frozen product will be. You'll save time, too, with less culling and sorting to do.

- 3. Proper packaging.** Use food wraps designed especially for freezing.

To freeze meat, **fish** and poultry, wrap well in freezer-weight foil (or other heavy-duty wrapping material), forming it carefully to the shape of the contents. This expels air. Fold and crimp ends of the package to provide a good, lasting seal.

Don't refreeze meat that has been completely thawed; meat, whether raw or cooked, can be frozen successfully only once.

Fine-quality ice cream, with high cream content, will normally require slightly lower temperatures than more "airy" already-packaged brands with low cream content.

- It will be necessary to experiment to determine the freezer compartment location and temperature control setting to keep your ice cream at the right serving temperature.
- The rear of the freezer compartment is slightly colder than the front.

Effervescent drinks should not be stored in freezer compartment.

STORAGE DRAWERS

Fruit and Vegetable Drawers

The storage drawers at the bottom of the fresh food compartment are designed to provide high humidity levels required by most vegetables and lower humidity levels required for most fruits.

When replacing the drawers, always push them all the way in.

Storage time will depend upon the type of food and its condition when placed in the drawers.

Excess water that you may find in the bottom of the drawers should be emptied and the drawers wiped dry.

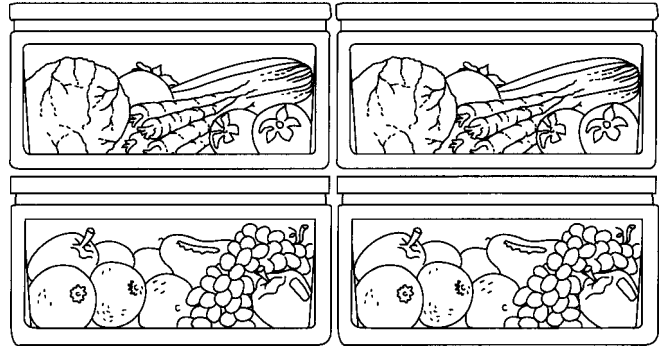

Sealed Drawers

This refrigerated drawer is designed to keep unwrapped foods fresh by retaining the natural moisture content of foods such as:

- Artichokes
- Celery
- Lettuce
- Rhubarb
- Asparagus
- Cherries
- Parsley
- Spinach
- Beets, topped
- Corn
- Peas, green
- Tomatoes, ripe
- Blueberries
- Currants
- Plums
- Carrots
- Greens, leafy
- Radishes

As in any refrigerated storage area, it is recommended that foods with strong odors be stored wrapped—foods such as:

- Broccoli
- Cabbage
- Parsnips
- Brussels sprouts
- Cauliflower
- Turnips
- Green onions

Unsealed Drawers

This refrigerated drawer is designed to provide lower humidity storage for items such as:

- Apples
- Nectarines
- Raspberries
- Apricots
- Oranges
- Squash, summer
- Grapes
- Peaches
- Strawberries
- Mushrooms
- Pears
- Tangerines

Sealed Snack Pan

The Sealed Snack Pan retains high humidity for the convenient storage of meats and cheese, bacon, hors d'oeuvres, spreads and snacks.

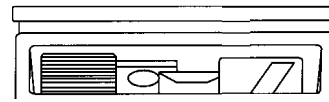

SHELVES

How to Rearrange Your Shelves

Adjustable Shelves in Both Compartments

Tempered glass shelves in the fresh food compartment and steel wire shelves in the freezer compartment are adjustable, enabling you to make efficient shelf arrangements to fit your family's food storage needs.

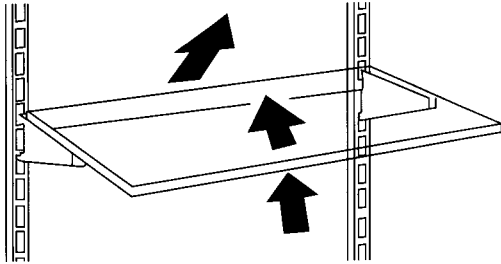

To remove shelves: Tilt shelf up at front, then lift it up and out of tracks on rear wall of refrigerator.

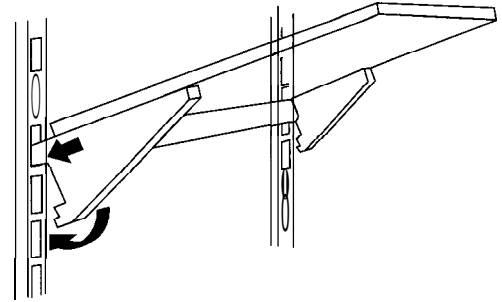

To replace shelves: Select desired shelf height. With shelf front raised slightly, engage top lugs in tracks at rear of cabinet. Then lower front of shelf until it locks into position.

Removable Wine Rack (on some models)

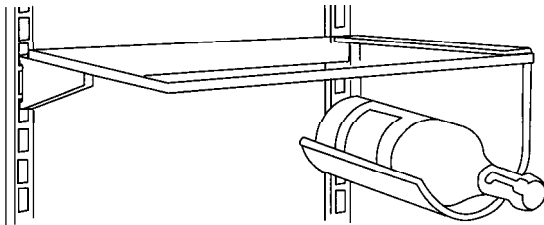

The wine rack is designed to hold a bottle on its side and will fit on any shelf.

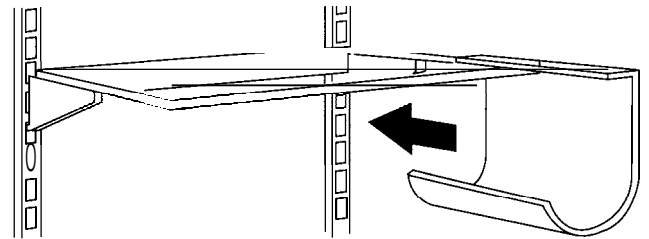

To relocate the wine rack:

Pull the wine rack straight out, position its lip over the right edge of the shelf you want to suspend it from and push it all the way in.

Adjustable Shelves on Both Doors

Door shelves can be moved up and down to meet your storage requirements.

To remove: Lift the shelf up and slide it towards you.

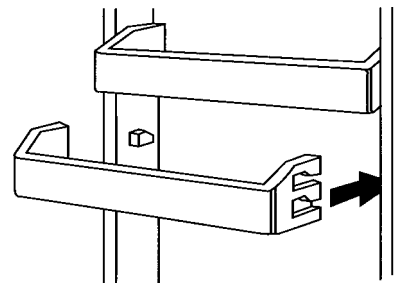

CARE AND CLEANING

Cleaning—Outside

The **water and ice dispenser spill shelf** should be wiped dry immediately to prevent spotting. Water left on the shelf may leave deposits that you can remove by soaking in undiluted vinegar. You can also use a paste of non-precipitating water softener (such as Calgon brand) and water, or one teaspoon of citric acid powder per pint of hot tap water. Soak until the deposit disappears or becomes loose enough to rinse away. Usually 30 minutes soaking time is adequate. Avoid using wax on the spill shelf and trim.

The door handles and trim can be cleaned with a cloth dampened with a solution of mild liquid dishwashing detergent and water. Dry with a soft cloth. Don't use wax on the door handles or trim.

Cleaning—Inside

Inside the fresh food and freezer compartments should be cleaned at least once a year. Unplug the refrigerator before cleaning. If this is not practical, wring excess moisture out of sponge or cloth when cleaning around switches, lights or controls.

Use warm water and baking soda solution—about a tablespoon of baking soda to a quart of water. This both cleans and neutralizes odors. Rinse thoroughly with water and wipe dry.

Other parts of the refrigerator—including door gaskets, meat and vegetable drawers, ice storage bin and all plastic parts—can be cleaned the same way. After cleaning door gaskets, apply a thin layer of petroleum jelly to the door gaskets at the hinge side. This helps keep the gaskets from sticking and bending out of shape. Do not use cleansing powders or other abrasive cleaners.

To help prevent odors, leave an open box of baking soda in the rear of the refrigerator, on the top shelf. Change the box every three months. An open box of baking soda in the freezer will absorb stale freezer odors.

Do not wash any plastic parts from your refrigerator in your automatic dishwasher.

CARE AND CLEANING

(continued)

Condenser

To clean the condenser fins:

First turn off the power at the circuit breaker or fuse box. Wait about 30 minutes for the condenser area to cool. Then remove the decorative panel by lifting up and toward you.

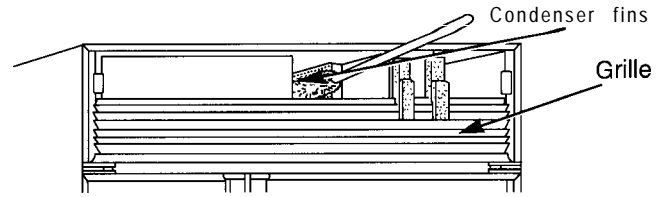
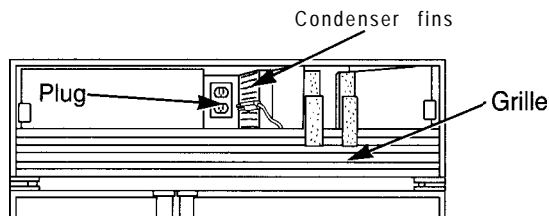
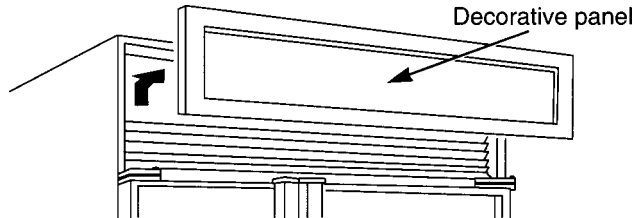

Use a soft bristle brush to loosen dust and lint on the condenser fins. Use a vacuum hose to remove soil.

After cleaning: Reconnect power at the fuse box or circuit breaker.

Replace the decorative panel.

CAUTION: The grille below the decorative panel provides necessary air circulation. Do not cover or alter the grille or damage to the cooling unit may occur.

Light bulb replacement in the fresh food compartment

There are upper and lower light bulbs in the fresh food compartments.

To replace a bulb:

1. Turn off power at the circuit breaker or fuse box.
2. Remove the light shield from the top fresh food light by pushing the front end up and pulling it toward you to release it from the rear retaining lip. (It may bend slightly.)

To change the bottom refrigerator light, pull out the top drawer, look to the rear of the fresh food compartment and replace bulb as needed.

3. Replace with the same size bulb, reinstall the shield for the upper fresh food light, and turn the power on.

To reinstall the upper fresh food shield, hook the front edge first, then push it up and back until the shield rests in place.

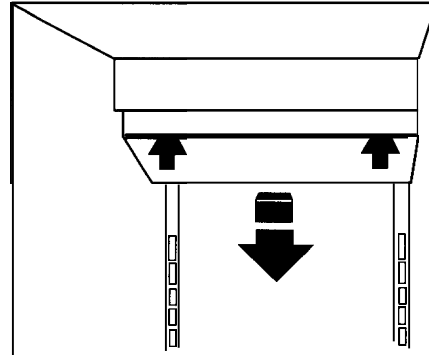

Light bulb replacement in the freezer compartment

To replace a bulb:

1. Turn off power at the circuit breaker or fuse box.
2. Remove the freezer light shield by pulling the front edge down and free and then pull it toward you.
3. Replace with the same size bulb, reinstall the shield, and turn the power on.

To replace the freezer shield, set the back edge on the rear tabs and then push up in the front until it rests in place.

You may bend the shield slightly to help in removal and replacement.

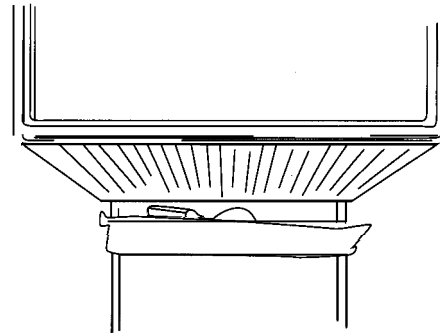

(continued next page)

CARE AND CLEANING

(continued)

Drawer and Cover Removal

Drawers at the bottom of the fresh food compartment will stop before coming all the way out of the refrigerator, to help prevent contents from spilling onto floor. These drawers can be removed easily by grasping the sides and lifting up slightly while pulling drawer past “stop” location.

1. Remove food from the shelf above the upper drawer and take out the shelf.
2. Pull the upper drawer forward and lift the front to clear the stops.

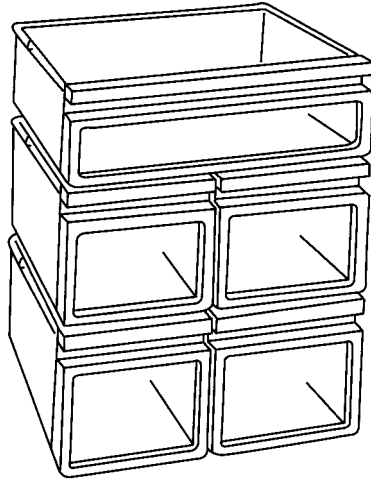

To remove drawers and their covers when the refrigerator door cannot be opened fully:

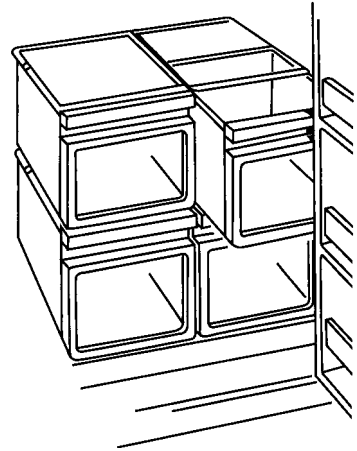

1. Pull the upper drawer partway out. Reach in, push the cover up; tilt it and take it out.
2. Roll the drawer forward and up, tilt the drawer and take it out.

Remove the lower drawer the same way.

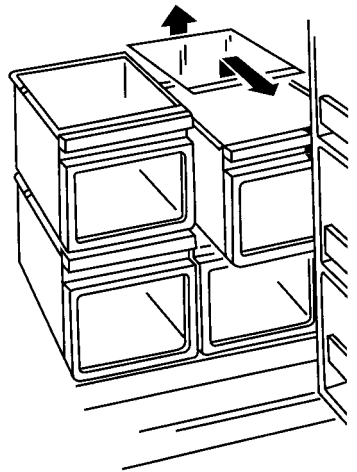

When you go on vacation

For extended vacations or absences, remove food and shut off power to the refrigerator at the fuse box or circuit breaker. Clean the interior with a baking soda solution of one tablespoon of soda to one quart of water. Wipe dry. To prevent odors, leave an open box of soda in the refrigerator. Leave doors open.



For shorter vacations, remove perishable foods and leave controls at regular settings. However, if the room temperature is expected to drop below 60°F., follow the same instructions as for extended vacations.

Move the **icemaker** feeler arm to the STOP (up) position and be sure to shut off the water supply to the refrigerator.

INSTALLATION REQUIREMENTS

IMPORTANT...Please Read Carefully.

How to connect electricity

For personal safety, this appliance must be properly grounded.

The power cord of this appliance is equipped with a three-prong (grounding) plug which mates with a standard three-prong (grounding) wall outlet (Fig. 1) to minimize the possibility of electric shock hazard from this appliance.

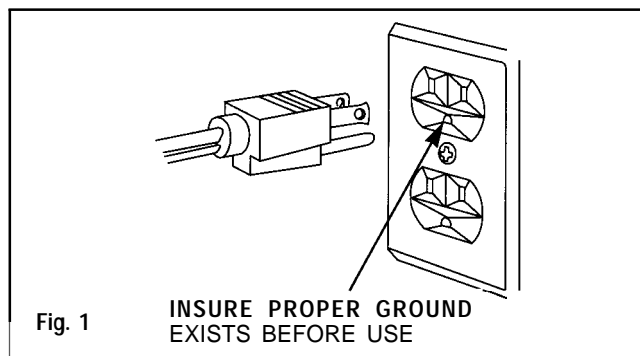

Have wall outlet and circuit checked by a qualified electrician to make sure outlet is properly grounded.

Where a standard two-prong wall outlet is encountered, it is your personal responsibility and obligation to have it replaced with a properly grounded three-prong wall outlet.

DO NOT, UNDER ANY CIRCUMSTANCES, CUT OR REMOVE THE THIRD (GROUND) PRONG FROM THE POWER CORD.

DO NOT USE AN ADAPTER PLUG TO CONNECT THE REFRIGERATOR TO A TWO-PRONG OUTLET.

DO NOT USE AN EXTENSION CORD WITH THIS APPLIANCE.

The refrigerator should always be plugged into its own individual electrical outlet—(115 volt, 60 Hertz, single phase AC—protected by a 20-amp time delay fuse or circuit breaker). This is recommended for best performance and to prevent overloading house wiring circuits, which could cause a fire hazard from overheating wires.

IMPORTANT: The water line and the electrical outlet must be installed in the exact location described in the Installation Instructions (Pub. No. 49-6457).

Refrigerator Location

Install the refrigerator on a floor strong enough to support it when it is fully loaded.

Do not install refrigerator where temperature will go below 60°F. because it will not run often enough to maintain proper temperatures.

Clearances

If the refrigerator is to be installed in a corner, allow 2" between the hinges of the refrigerator and the wall to assure a 90° door opening capability.

No other clearances at top, sides or back are required.

Leveling

This model has 4-point leveling. All four corners are supported by leveling legs. The front wheels are non-adjustable; they are only used for positioning the unit.

- To level the back of the unit, turn hex nut located above the front wheels.
- To level the front of the unit, use a 1 1/4" open end wrench and adjust the leveling legs.
- Turn hex nut or front leveling leg clockwise to raise the unit, counter-clockwise to lower the unit.

See the Installation Instructions (Pub. No. 49-6457) for complete directions.

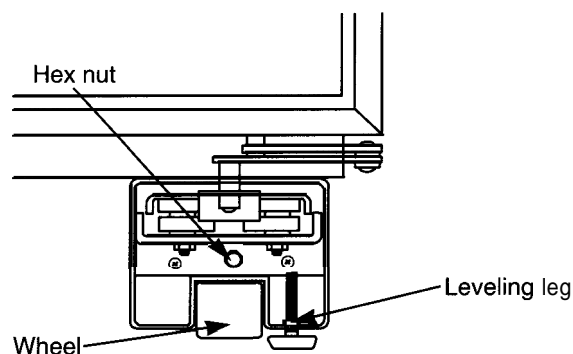

QUESTIONS? USE THIS PROBLEM SOLVER

PROBLEM	POSSIBLE CAUSE
REFRIGERATOR DOES NOT OPERATE	<ul style="list-style-type: none"> • May be in defrost cycle when motor does not operate for about 30 minutes. • Temperature control is in OFF position. • If the interior light is not on, the refrigerator may not be plugged in at the wall outlet. • If the plugs are secure and the refrigerator still fails to operate, plug a lamp into the same outlet to determine if there is a tripped circuit breaker or burned out fuse.
MOTOR OPERATES FOR LONG PERIODS	<ul style="list-style-type: none"> • Modern refrigerators with more storage space and a larger freezer compartment require more operating time. • Normal when refrigerator is first delivered to your home—usually requires 24 hours to completely cool down. • Large amounts of food placed in refrigerator to be cooled or frozen. • Hot weather—frequent door openings. • Door left open. • Temperature controls are set too cold. • Condenser needs cleaning.
MOTOR STARTS & STOPS FREQUENTLY	<ul style="list-style-type: none"> • Temperature control starts and stops motor to maintain even temperatures.
VIBRATION OR RATTLING	<ul style="list-style-type: none"> • If refrigerator vibrates, more than likely it is not resting solidly on the floor. The front leveling legs need adjusting, or floor is weak or uneven. Adjust levelers or call your installer. • If dishes vibrate on shelves, try moving them. Slight vibration is normal.
OPERATING SOUNDS	<ul style="list-style-type: none"> • The high speed compressor motor required to maintain near zero temperatures in the large freezer compartment may produce higher sound levels than your old refrigerator. • Normal fan air flow—one fan blows cold air through the refrigerator and freezer compartments—another fan cools the compressor motor. • These NORMAL sounds will also be heard from time to time: <ul style="list-style-type: none"> • Defrost timer switch clicks at defrost. • Defrost water dripping. • Temperature control clicks ON or OFF. • Refrigerant boiling or gurgling. • Cracking or popping of cooling coils caused by expansion and contraction during defrost and refrigeration following defrost. • Ice cubes dropping into the bin and water running in pipes as icemaker refills.
FOODS DRY OUT	<ul style="list-style-type: none"> • Foods not covered, wrapped or sealed properly.
FRESH FOOD OR FREEZER COMPARTMENT TEMPERATURE TOO WARM	<ul style="list-style-type: none"> • Temperature control not set cold enough. • Warm weather—frequent door openings. • Door left open for too long a time. • Package may be holding door open.

PROBLEM	POSSIBLE CAUSE
DOORS NOT CLOSING PROPERLY	<ul style="list-style-type: none"> • Refrigerator not level. Adjust levelers or call the installer. When cabinet is level, doors will close gently and securely.
FROST OR ICE CRYSTALS ON FROZEN FOOD	<ul style="list-style-type: none"> • Door may have been left ajar or package holding door open. • Too frequent or too long door openings. • Frost within package is normal.
AUTOMATIC ICEMAKER DOES NOT WORK	<ul style="list-style-type: none"> • Icemaker feeler arm in STOP (up) position. • Water supply turned off or not connected. • Freezer compartment too warm. • Cubes too small—water shutoff valve connecting refrigerator to home water line may be clogged. • Sometimes cubes fuse to the side of the ice mold and hold the feeler arm in the STOP (up) position. Remove this ice to restart the icemaker. • When reaching for cubes by hand, you may have pushed the feeler arm into the STOP (up) position by mistake. • Piled up cubes in storage bin may cause icemaker to shut off prematurely. With icemaker feeler arm in STOP (up) position, level cubes in bin by hand.
SLOW ICE CUBE FREEZING	<ul style="list-style-type: none"> • Door may have been left open. • Turn temperature of freezing compartment colder.
ICE CUBES HAVE ODOR/TASTE	<ul style="list-style-type: none"> • Old cubes need to be discarded. • Ice storage bin needs to be emptied and washed. • Unsealed packages in refrigerator and/or freezer compartments may be transmitting odor/taste to ice cubes. • Interior of refrigerator needs cleaning. • Poor-tasting incoming water. Install a water filter.
CUBE DISPENSER DOES NOT WORK	<ul style="list-style-type: none"> • No ice cubes. Remove storage bin. If cubes are frozen to wire arm, remove cubes. • No ice cubes. Icemaker turned off or water supply turned off. • Irregular ice clumps in storage container. Break up as many as you can with fingertip pressure and discard the remaining clumps.
WATER HAS POOR TASTE/ODOR	<ul style="list-style-type: none"> • If water dispenser has not been used for an extended period, dispense water in regular manner until all water in reservoir is replenished with fresh water. • Poor-tasting incoming water. Install a water filter. See the Water Filter Accessory section of this book.
WATER IN FIRST GLASS IS WARM	<ul style="list-style-type: none"> • Allow about 24 hours for water to cool to proper temperature after refrigerator is first installed. • If water dispenser has not been used for extended period, water in first glass will not be as cool as in succeeding glasses. • If water reservoir has been drained, allow several hours for replenished supply to chill.

(continued next page)

PROBLEM SOLVER

(continued)

PROBLEM	POSSIBLE CAUSE
WATER DISPENSER DOES NOT WORK	<ul style="list-style-type: none"> • Water supply line turned off or not connected. • Supply line may be clogged with sediment.
MOISTURE FORMS ON CABINET SURFACE BETWEEN THE DOORS	<ul style="list-style-type: none"> • Not unusual during periods of high humidity. If problem persists, call for service.
MOISTURE COLLECTS INSIDE	<ul style="list-style-type: none"> • Too frequent or too long door openings. • In humid weather, air carries moisture into refrigerator when doors are opened.
WATER ON FLOOR	<ul style="list-style-type: none"> • The drain at the bottom of the freezer may be clogged. Remove any ice on the freezer bottom and clean the drain. • If you use a glass over 6 inches tall, you may be jamming the cubes in the funnel chute. They can fuse inside the chute and drop out later, leaving water or ice on the floor.
REFRIGERATOR HAS ODOR	<ul style="list-style-type: none"> • Foods with strong odors should be tightly covered. • Check for spoiled food. • Interior needs cleaning. • Keep open box of baking soda in refrigerator; replace every three months.
INTERIOR LIGHT DOES NOT WORK	<ul style="list-style-type: none"> • No power at outlet. Call installer or electrician. • Light bulb needs replacing. • Check fuse and circuit breaker.
UNEVEN SPACING OR GAPS BETWEEN DOORS AND KITCHEN CABINETS	<ul style="list-style-type: none"> • Kitchen cabinets are not level or square. Call the installer or cabinet maker.
POOR DOOR ALIGNMENT OR ONE DOOR HIGHER THAN THE OTHER	<ul style="list-style-type: none"> • Refrigerator not level. Adjust levelers so refrigerator is resting solidly on the floor and is level side to side and front to back.

If you need more help... call, toll free:
GE Answer Center™
800.626.2000
consumer information service

NOTES

With the purchase of your new Monogram appliance, receive the assurance that if you ever need information or assistance from GE, we'll be there. All you have to do is call—toll-free!

In-Home Repair Service ***800-GE-CARES (800432-2737)***

AGE consumer service professional will provide expert repair service, scheduled at a time that's convenient for you. Many GE Consumer Service company-operated locations offer you service today or tomorrow, or at your convenience (7:00 a.m. to 7:00 p.m. weekdays, 9:00 a.m. to 2:00 p.m. Saturdays). Our factory-trained technicians know your appliance inside and out—so most repairs can be handled in just one visit.

GE Answer Center[®] ***800.626.2000***

Whatever your question about any Monogram major appliance, GE Answer Center[®] information service is available to help. Your call—and your question—will be answered promptly and courteously. And you can call any time. GE Answer Center[®] service is open 24 hours a day, 7 days a week.

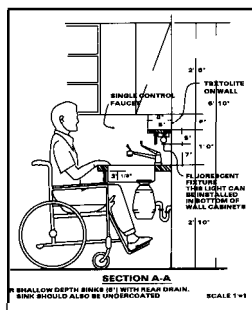

For Customers With Special Needs... ***800.626.2000***

Upon request, GE will provide Braille controls for a variety of Monogram appliances, and a brochure to assist in planning a barrier-free kitchen for persons with limited mobility. To obtain these items, free of charge, call 800.626.2000.

Consumers with impaired hearing or speech who have access to a TDD or a conventional teletypewriter may call 800-TDD-GEAC (800-833-4322) to request information or service.

Service Contracts ***800-626-2224***

You can have the secure feeling that GE Consumer Service will still be there after your warranty expires. Purchase a GE contract while your warranty is still in effect and you'll receive a substantial discount. With a multiple-year contract, you're assured of future service at today's prices.

Parts and Accessories ***800-626-2002***

Individuals qualified to service their own appliances can have needed parts or accessories sent directly to their home. The GE parts system provides access to over 47,000 parts... and all GE Genuine Renewal Parts are fully warranted. VISA, MasterCard and Discover cards are accepted.

User maintenance instructions contained in this booklet cover procedures intended to be performed by any user. Other servicing generally should be referred to qualified service personnel. Caution must be exercised, since improper servicing may cause unsafe operation.

YOUR MONOGRAM REFRIGERATOR WARRANTY

Save proof of original purchase date such as your sales slip or cancelled check to establish warranty period.

WHAT IS COVERED

FULL ONE-YEAR WARRANTY

For one year from date of original purchase, we will provide, free of charge, parts and service labor in your home to repair or replace **any part of the refrigerator** that fails because of a manufacturing defect,

FULL FIVE-YEAR WARRANTY

For five years from date of original purchase, we will provide, free of charge, parts and service labor in your home to repair or replace any part of the sealed refrigerating system (the compressor, condenser, evaporator and all connecting tubing) that fails because of a manufacturing defect.

This warranty is extended to the original purchaser and any succeeding owner for products purchased for ordinary home use in the 48 mainland states, Hawaii and Washington, D.C. In Alaska the warranty is the same except that it is LIMITED because you must pay to ship the product to the service shop or for the service technician's travel costs to your home.

All warranty service will be provided by our Factory Service Centers or by our authorized Customer Care® servicers during normal working hours.

Should your appliance need service, during warranty period or beyond, call 800-GE-CARES, (800-432-2737).

WHAT IS NOT COVERED

- Service trips to your home to teach you how to use the product.

Read your Use and Care material. If you then have any questions about operating the product please contact your dealer or our Consumer Affairs office at the address below, or call, toll free:

GE Answer Center®
800.626.2000
consumer information service

- Improper installation.

If you have an installation problem, contact your dealer or installer. You are responsible for providing adequate electrical, plumbing and other connecting facilities.

- Replacement of house fuses or resetting of circuit breakers.
- Failure of the product if it is used for other than its intended purpose or used commercially.
- Damage to product caused by accident, fire, floods or acts of God.
- Loss of food due to spoilage.

WARRANTOR IS *NOT*
RESPONSIBLE FOR
CONSEQUENTIAL DAMAGES.

Some states do not allow the exclusion or limitation of incidental or consequential damages, so the above limitation or exclusion may not apply to you. This warranty gives you specific legal rights, and you may also have other rights which vary from state to state. To know what your legal rights are in your state, consult your local or state consumer affairs office or your state's Attorney General.

Warrantor: General Electric Company

If further help is needed concerning this warranty, write:
Manager—Consumer Affairs, GE Appliances, Louisville, KY 40225

ZIS48N
ZISB48D
ZISW48D



Monogram™

General Electric Company
Louisville, KY 40225

Pub.No. 49-6719
Part No.162 D3943P001
8072
11-92 CG